

BID ADVERTISEMENT FORM

Bid description	Labour for the Construction Handling Facility Occidental Ranch		
Bid number	NC/DALQ/1973		
Name of institution	Department of Agriculture, Land Reform & Rural Development		
The place where goods, works, or services are required	Occidental Ranch		
Closing date and time	Date	22 February 2021	Time
			11:00 AM
Contact details	Postal address	Department of Agriculture Private Bag X5018 Kimberley 8300 Attention: Ms Kushane	
	Physical address	Department of Agriculture 162 George Street Kimberley 8300 Attention: Ms Kushane	
	Tel. no.	053 838 9170	
	Fax no.	053 838 9151	
	E-mail address	jkushane@ncpg.gov.za	
	Contact person	Koos Jordaan 0834115482	
Where bids can be collected	Collected at site Briefing		
Where bids should be delivered	162 George Street, Kimberley 8300		
Category (refer to annexure A)	GRADE 1CE or Higher and 80/20 point system		
Sector	Other		
Region	JTG		
Compulsory briefing session/site visit	Date	18 February 2021	
	Time	10:00 AM	
	Venue	Farm Occidental Ranch]- Time [10:00]- Venue[Occidental Ranch co-ordinates 26°35'41" S - 23°26'24" E]	

PUBLICATION OF AWARD FORM



agriculture, land reform & rural development

Department:
agriculture, land reform & rural development
NORTHERN CAPE PROVINCE
REPUBLIC OF SOUTH AFRICA



PRICE QUOTATION R 200 000.00

NB: Use ink, preferably black, to fill in the information applicable to the specific required price quotation

PRICE QUOTATION NO:	NC/DALQ/1973	VALIDITY:	90 DAYS
CLOSING DATE:	22 February 2021	CLOSING TIME:	11:00 AM
CONTACT PERSON:	Koos Jordaan	CONTACT NO:	0834115482
PROJECT DISCRPTION :	Labour for the Construction Handling Facility Occidental Ranch		
PROJECT:	Commercialization of black producers	FUND:	Casp 2021
MINIMUM CIDB REGISTRATION REQUIRED		1CE	



ITEM	QTY	DESCRIPTION	PRICE IN RAND CURRENCY INCLUSIVE OF VAT
1	See provisional bill of quantities	Labour for the Construction Handling Facility Occidental Ranch	R

Trade mark and model:
 Country of origin:

Points claimed:

B-BBEE status level verification certificate appended?

YES OR NO

***NB: TICK APPLICABLE BLOCK**

ISSUING AGENCY _____

- Delivery basis:

(i) Is the delivery period firm? ***YES / NO**

(ii) Period required for delivery after receipt of order.....

- Is the price (inclusive of VAT) firm? ***YES / NO**

- Discount offered (conditional/unconditional):

- Is offer strictly to specification/terms of reference, if attached? ***YES / NO**

If not to specification/terms of reference, state deviation(s)

(1) Name of taxpayer/tenderer:

(2) Identification Document number:

(3) Trade name:

Company/Close Corporation registration number:

(5) Income tax reference number:

(Original of Income Tax Clearance Certificate to be attached)

(6) VAT registration number (if applicable):

(7) PAYE employer's registration number (if applicable)

Bank Details (if applicable):

Bank Name:

Bank Branch Code:

--	--	--	--	--	--

Account Holder:

Bank Account number:

--	--	--	--	--	--	--	--	--	--	--	--	--	--	--	--	--	--	--	--

Bank account type:

Contact person:

Signature: **Name in print:**

Telephone No.: **Code:** **No.**

Fax No.: **Code:** **No.**

E-mail address:

Address:

.....
..... **Postal code:**

--	--	--	--

SIGNATURE

SURNAME & INITIALS

DATE

REMINDER: PLEASE TAKE NOTE

IT CAME TO THE ATTENTION OF THE DEPARTMENT THAT PREVENTABLE MISTAKES OCCUR IN THE COMPLETION OF YOUR BID DOCUMENTS. THIS LEADS TO YOUR BIDS BEING INVALIDATED AND/OR DISQUALIFIED AND LOSING BBB-EE POINTS.

THE MOST COMMON MISTAKES ARE THE FOLLOWING:

- 1 COPY OF ID & COMPANY REGISTRATION (CERTIFIED)
- 2 NON INCLUSION OF ORIGINAL TAX CLEARANCE/SARS PIN
- 3 THE USE OF CORRECTIONAL FLUID/TAPE
- 4 THE INCLUSION OF AN UNCERTIFIED COPY OF A SANAS ACREDIDATE BBB-EE CERTIFICATE/ A COPY OF A SWORN BBB-EE AFFIDAVIT
- 5 THE OMISSION OF A FINAL BID PRICE
- 6 THE OMISSION OF THE DELIVERY PERIOD
- 7 PLEASE DOUBLE CHECK YOUR CALCULATIONS AS MISCALCULATIONS LEADS TO UNNECESSARY DELAYS AND MAY ALSO LEAD TO INVALIDATION
- 8 FAILURE TO SIGN ANY FORM WHERE YOUR SIGNATURE IS REQUIRED, WILL LEAD TO DISQUALIFICATION
- 9 FAILING TO INCLUDE CSD REGISTRATION OR UNIQUE SUPPLIER NUMBER

THE PRICE QUOTATION BOX IS SITUATED AT TEMOTHUO HOUSE, 162 GEORGE STREET, KIMBERLEY AT THE MAIN ENTRANCE TO THE DEPARTMENT (NOT THE STREET ENTRANCE). PLEASE ENSURE THAT YOUR BIDS ARE DEPOSITED IN THIS BOX BEFORE THE OFFICIAL CLOSING TIME AND DATE OF THE BID.

TAX CLERANCE CERTIFICATE REQUIREMENTS

It is a condition of bid that the taxes of the successful bidder must be in order, or that satisfactory arrangements have been made with South African Revenue Service (SARS) to meet the bidder's tax obligations.

- 1) In order to meet this requirement bidders are required to complete in full the attached form TCC 001 "Application for a Tax Clearance Certificate" and submit it to any SARS branch office nationally. The Tax Clearance Certificate Requirements are also applicable to foreign bidders/ individuals who wish to submit bids.
- 2) SARS will then furnish the bidder with a Tax Clearance Certificate that will be valid for a period 1 (one) year from the date of approval.
- 3) The original Tax Clearance Certificate must be submitted together with the bid. Failure to submit the original and valid Tax Clearance Certificate will result in the invalidation of the bid. Certified copies of the Tax Clearance Certificate will not be acceptable. Note: For tenders (bids) a Tax Clearance Certificate for tender is required. For quotations a Tax Clearance Certificate for good standing is required.
- 4) In bids where Consortia/ Joint Ventures/ Sub- contractors are involved, each party must submit a separate Tax Clearance Certificate/Sars Pin
- 5) Copies of the TCC 001 "Application for Tax Clearance Certificate" form are available from any SARS branch office nationally or on the website www.sars.gov.za.
- 6) Application for the Tax Clearance Certificates may also be made via eFiling. In order to use this provision, taxpayers will need to register with SARS as efilers through the website www.sars.gov.za

DECLARATION OF INTEREST

1. Any legal person, including persons employed by the state¹, or persons having a kinship with persons employed by the state, including a blood relationship, may make an offer or offers in terms of this invitation to bid (includes an advertised competitive bid, a limited bid, a proposal or written price quotation). In view of possible allegations of favouritism, should the resulting bid, or part thereof, be awarded to persons employed by the state, or to persons connected with or related to them, it is required that the bidder or his/her authorised representative declare his/her position in relation to the evaluating/adjudicating authority where-

- the bidder is employed by the state; and/or
- the legal person on whose behalf the bidding document is signed, has a relationship with persons/a person who are/is involved in the evaluation and or adjudication of the bid(s), or where it is known that such a relationship exists between the person or persons for or on whose behalf the declarant acts and persons who are involved with the evaluation and or adjudication of the bid.

2. In order to give effect to the above, the following questionnaire must be completed and submitted with the bid.

2.1 Full Name of bidder or his or her representative:.....

2.2 Identity Number:.....

2.3 Position occupied in the Company (director, trustee, shareholder², member):
.....

2.4 Registration number of company, enterprise, close corporation, partnership agreement or trust:
.....

2.5 Tax Reference Number:.....

2.6 VAT Registration Number:

2.6.1 The names of all directors / trustees / shareholders / members, their individual identity numbers, tax reference numbers and, if applicable, employee / PERSAL numbers must be indicated in paragraph 3 below.

¹“State” means –

- (a) any national or provincial department, national or provincial public entity or constitutional institution within the meaning of the Public Finance Management Act, 1999 (Act No. 1 of 1999);
- (b) any municipality or municipal entity;
- (c) provincial legislature;
- (d) national Assembly or the national Council of provinces; or
- (e) Parliament.

²“Shareholder” means a person who owns shares in the company and is actively involved in the management of the enterprise or business and exercises control over the enterprise.

2.7 Are you or any person connected with the bidder presently employed by the state? YES / NO

2.7.1 If so, furnish the following particulars:

Name of person / director / trustee / shareholder/ member.....
Name of state institution at which you or the person connected to the bidder is employed.....
Position occupied in the state institution.....

Any other particulars:

.....
.....
.....

2.7.2 If you are presently employed by the state, did you obtain the appropriate authority to undertake remunerative work outside employment in the public sector? YES / NO

2.7.2.1 If yes, did you attach proof of such authority to the bid document? YES / NO

(Note: Failure to submit proof of such authority, where applicable, may result in the disqualification of the bid.

2.7.2.2 If no, furnish reasons for non-submission of such proof:

.....
.....
.....

2.8 Did you or your spouse, or any of the company's directors / trustees / shareholders / members or their spouses conduct business with the state in the previous twelve months? YES / NO

2.8.1 If so, furnish particulars:

.....
.....
.....

2.9 Do you, or any person connected with the bidder, have any relationship (family, friend, other) with a person employed by the state and who may be involved with the evaluation and or adjudication of this bid? YES / NO

2.9.1 If so, furnish particulars.

.....
.....
.....

2.10 Are you, or any person connected with the bidder, YES/NO
 aware of any relationship (family, friend, other) between
 any other bidder and any person employed by the state
 who may be involved with the evaluation and or adjudication
 of this bid?

2.10.1 If so, furnish particulars.

2.11 Do you or any of the directors / trustees / shareholders / members YES/NO
 of the company have any interest in any other related companies
 whether or not they are bidding for this contract?

2.11.1 If so, furnish particulars:

3. FULL DETAILS OF DIRECTORS / TRUSTEES / MEMBERS / SHAREHOLDERS.

Full Name	Identity Number	Personal Income Tax Reference Number	State Employee Number / Peral Number

4 DECLARATION
 I, THE UNDERSIGNED (NAME).....
 CERTIFY THAT THE INFORMATION FURNISHED IN PARAGRAPHS 2 and 3 ABOVE IS CORRECT.
 I ACCEPT THAT THE STATE MAY REJECT THE BID OR ACT AGAINST ME SHOULD THIS
 DECLARATION PROVE TO BE FALSE.

.....
 Signature Date

.....
 Position Name of bidder

PREFERENCE POINTS CLAIM FORM IN TERMS OF THE PREFERENTIAL PROCUREMENT REGULATIONS 2017

This preference form must form part of all bids invited. It contains general information and serves as a claim form for preference points for Broad-Based Black Economic Empowerment (B-BBEE) Status Level of Contribution

NB: BEFORE COMPLETING THIS FORM, BIDDERS MUST STUDY THE GENERAL CONDITIONS, DEFINITIONS AND DIRECTIVES APPLICABLE IN RESPECT OF B-BBEE, AS PRESCRIBED IN THE PREFERENTIAL PROCUREMENT REGULATIONS, 2017.

1. GENERAL CONDITIONS

1.1 The following preference point systems are applicable to all bids:

- a. the 80/20 system for requirements with a Rand value of up to **R50 000 000** (all applicable taxes included); and
- b. the 90/10 system for requirements with a Rand value above **R50 000 000** (all applicable taxes included).

1.2 The value of this bid is estimated to not exceed R50 000 000 (all applicable taxes included) and therefore the 80/20 preference point system shall be applicable

1.3 Points for this bid shall be awarded for:

- a) Price; and
- b) B-BBEE Status Level of Contributor.

1.4 The maximum points for this bid are allocated as follows:

	POINTS
PRICE	80
B-BBEE STATUS LEVEL OF CONTRIBUTOR	20
Total points for Price and B-BBEE must not exceed	100

1.5 Failure on the part of a bidder to submit proof of B-BBEE Status level of contributor together with the bid, will be interpreted to mean that preference points for B-BBEE status level of contribution are not claimed.

1.6 The purchaser reserves the right to require of a bidder, either before a bid is adjudicated or at any time subsequently, to substantiate any claim in regard to preferences, in any manner required by the purchaser.

2. DEFINITIONS

- a) **“B-BBEE”** means broad-based black economic empowerment as defined in section 1 of the Broad-Based Black Economic Empowerment Act;
- b) **“B-BBEE status level of contributor”** means the B-BBEE status of an entity in terms of a code of good practice on black economic empowerment, issued in terms of section 9(1) of the Broad-Based Black Economic Empowerment Act;
- c) **“bid”** means a written offer in a prescribed or stipulated form in response to an invitation by an organ of state for the provision of goods or services, through price quotations, advertised competitive bidding processes or proposals;
- d) **“Broad-Based Black Economic Empowerment Act”** means the Broad-Based Black Economic Empowerment Act, 2003 (Act No. 53 of 2003);

- e) **“EME”** means an Exempted Micro Enterprise in terms of a code of good practice on black economic empowerment issued in terms of section 9 (1) of the Broad-Based Black Economic Empowerment Act;
- f) **“functionality”** means the ability of a tenderer to provide goods or services in accordance with specifications as set out in the tender documents.
- g) **“prices”** includes all applicable taxes less all unconditional discounts;
- h) **“proof of B-BBEE status level of contributor” means:**
 1. B-BBEE Status level certificate issued by an authorized body or person;
 2. A sworn affidavit as prescribed by the B-BBEE Codes of Good Practice;
 3. Any other requirement prescribed in terms of the B-BBEE Act;
- i) **“QSE”** means a qualifying small business enterprise in terms of a code of good practice on black economic empowerment issued in terms of section 9 (1) of the Broad-Based Black Economic Empowerment Act;
- j) **“rand value”** means the total estimated value of a contract in Rand, calculated at the time of bid invitation, and includes all applicable taxes;

3. POINTS AWARDED FOR PRICE

3.1 THE 80/20 OR 90/10 PREFERENCE POINT SYSTEMS

A maximum of 80 or 90 points is allocated for price on the following basis:
80/20 or 90/10

$$P_s = 80 \left(1 - \frac{P_t - P_{min}}{P_{min}} \right) \quad \text{or} \quad P_s = 90 \left(1 - \frac{P_t - P_{min}}{P_{min}} \right)$$

Where:

- P_s = Points scored for price of bid under consideration
- P_t = Price of bid under consideration
- P_{min} = Price of lowest acceptable bid

4. POINTS AWARDED FOR B-BBEE STATUS LEVEL OF CONTRIBUTOR

4.1 IN TERMS OF REGULATION 6 (2) AND 7 (2) OF THE PREFERENTIAL PROCUREMENT REGULATIONS, PREFERENCE POINTS MUST BE AWARDED TO A BIDDER FOR ATTAINING THE B-BBEE STATUS LEVEL OF CONTRIBUTION IN ACCORDANCE WITH THE TABLE BELOW:

B-BBEE Status Level of Contributor	Number of points (90/10 system)	Number of points (80/20 system)
1	10	20
2	9	18
3	6	14
4	5	12
5	4	8
6	3	6
7	2	4
8	1	2
Non-compliant contributor	0	0

5. BID DECLARATION

5.1 Bidders who claim points in respect of B-BBEE Status Level of Contribution must complete the following:

6. B-BBEE STATUS LEVEL OF CONTRIBUTOR CLAIMED IN TERMS OF PARAGRAPHS 1.4 AND 4.1

6.1 B-BBEE Status Level of Contributor: = (maximum of 10 or 20 points)

(Points claimed in respect of paragraph 6.1 must be in accordance with the table reflected in paragraph 4.1 and must be substantiated by relevant proof of B-BBEE status level of contributor.

7. SUB-CONTRACTING

7.1 Will any portion of the contract be sub-contracted?

(Tick applicable box)

YES	<input type="checkbox"/>	NO	<input type="checkbox"/>
-----	--------------------------	----	--------------------------

7.1.1 If yes, indicate:

1. What percentage of the contract will be subcontracted.....%
2. The name of the sub-contractor.....
3. The B-BBEE status level of the sub-contractor.....
4. Whether the sub-contractor is an EME or QSE

(Tick applicable box)

YES	<input type="checkbox"/>	NO	<input type="checkbox"/>
-----	--------------------------	----	--------------------------

Specify, by ticking the appropriate box, if subcontracting with an enterprise in terms of Preferential Procurement Regulations, 2017:

Designated Group: An EME or QSE which is at least 51% owned by:	EME	QSE
	<input type="checkbox"/>	<input type="checkbox"/>
Black people	<input checked="" type="checkbox"/>	<input checked="" type="checkbox"/>
Black people who are youth	<input type="checkbox"/>	<input type="checkbox"/>
Black people who are women	<input type="checkbox"/>	<input type="checkbox"/>
Black people with disabilities	<input type="checkbox"/>	<input type="checkbox"/>
Black people living in rural or underdeveloped areas or townships	<input type="checkbox"/>	<input type="checkbox"/>
Cooperative owned by black people	<input type="checkbox"/>	<input type="checkbox"/>
Black people who are military veterans	<input type="checkbox"/>	<input type="checkbox"/>
OR		
Any EME	<input type="checkbox"/>	<input type="checkbox"/>
Any QSE	<input type="checkbox"/>	<input type="checkbox"/>

8. DECLARATION WITH REGARD TO COMPANY/FIRM

8.1 Name of company/firm:

8.2 VAT registration number:

8.3 Company registration number:

8.4 TYPE OF COMPANY/ FIRM

- Partnership/Joint Venture / Consortium
- One person business/sole propriety
- Close corporation
- Company
- (Pty) Limited

[TICK APPLICABLE BOX]



8.5 DESCRIBE PRINCIPAL BUSINESS ACTIVITIES

.....
.....

8.6 COMPANY CLASSIFICATION

- Manufacturer
- Supplier
- Professional service provider
- Other service providers, e.g. transporter, etc.

[TICK APPLICABLE BOX]

8.7 MUNICIPAL INFORMATION

Municipality where business is situated:
Registered Account Number:
Stand Number:

8.8 Total number of years the company/firm has been in business:

8.9 I/we, the undersigned, who is / are duly authorised to do so on behalf of the company/firm, certify that the points claimed, based on the B-BBE status level of contributor indicated in paragraphs 1.4 and 6.1 of the foregoing certificate, qualifies the company/ firm for the preference(s) shown and I / we acknowledge that:

- (a) The information furnished is true and correct;
- (b) The preference points claimed are in accordance with the General Conditions as indicated in paragraph 1 of this form;
- (c) In the event of a contract being awarded as a result of points claimed as shown in paragraphs 1.4 and 6.1, the contractor may be required to furnish documentary proof to the satisfaction of the purchaser that the claims are correct;
- (d) If the B-BBEE status level of contributor has been claimed or obtained on a fraudulent basis or any of the conditions of contract have not been fulfilled, the purchaser may, in addition to any other remedy it may have –
 - disqualify the person from the bidding process;
 - recover costs, losses or damages it has incurred or suffered as a result of that person's conduct;
 - cancel the contract and claim any damages which it has suffered as a result of having to make less favourable arrangements due to such cancellation;
 - recommend that the bidder or contractor, its shareholders and directors, or only the shareholders and directors who acted on a fraudulent basis, be restricted by the National Treasury from obtaining business from any organ of state for a period not exceeding 10 years, after the audi alteram partem (hear the other side) rule has been applied; and
 - forward the matter for criminal prosecution.

WITNESSES	
1.
2.

SIGNATURE(S) OF BIDDERS(S)	
DATE:
ADDRESS

NCP8

DECLARATION OF BIDDER'S PAST SUPPLY CHAIN MANAGEMENT PRACTICES

1. This Standard Bidding Document must form part of all bids invited.
2. It serves as a declaration to be used by institutions in ensuring that when goods and services are being procured, all reasonable steps are taken to combat the abuse of the supply chain management system.
3. The bid of any bidder may be disregarded if that bidder, or any of its directors have-
 - a. abused the institution's supply chain management system;
 - b. committed fraud or any other improper conduct in relation to such system; or
 - c. failed to perform on any previous contract.
4. In order to give effect to the above, the following questionnaire must be completed and submitted with the bid.

Item	Question	Yes	No
4.1	Is the bidder or any of its directors listed on the National Treasury's Database of Restricted Suppliers as companies or persons prohibited from doing business with the public sector? (Companies or persons who are listed on this Database were informed in writing of this restriction by the Accounting Officer/Authority of the institution that imposed the restriction after the <i>audi alteram partem</i> rule was applied). The Database of Restricted Suppliers now resides on the National Treasury's website (www.treasury.gov.za) and can be accessed by clicking on its link at the bottom of the home page.	Yes <input type="checkbox"/>	No <input type="checkbox"/>
4.1.1	If so, furnish particulars:		
4.2	Is the bidder or any of its directors listed on the Register for Tender Defaulters in terms of section 29 of the Prevention and Combating of Corrupt Activities Act (No 12 of 2004)? The Register for Tender Defaulters can be accessed on the National Treasury's website (www.treasury.gov.za) by clicking on its link at the bottom of the home page.	Yes <input type="checkbox"/>	No <input type="checkbox"/>
4.2.1	If so, furnish particulars:		
4.3	Was the bidder or any of its directors convicted by a court of law (including a court outside of the Republic of South Africa) for fraud or corruption during the past five years?	Yes <input type="checkbox"/>	No <input type="checkbox"/>
4.3.1	If so, furnish particulars:		
4.4	Was any contract between the bidder and any organ of state terminated during the past five years on account of failure to perform on or comply with the contract?	Yes <input type="checkbox"/>	No <input type="checkbox"/>

4.4.1	If so, furnish particulars:
-------	-----------------------------

CERTIFICATION

I, THE UNDERSIGNED (FULL NAME) CERTIFY THAT THE INFORMATION FURNISHED ON THIS DECLARATION FORM IS TRUE AND CORRECT.

I ACCEPT THAT, IN ADDITION TO CANCELLATION OF A CONTRACT, ACTION MAY BE TAKEN AGAINST ME SHOULD THIS DECLARATION PROVE TO BE FALSE.

.....
Signature

.....
Date

.....
Position

.....
Name of Bidder

CERTIFICATE OF INDEPENDENT BID DETERMINATION

- 1 This Standard Bidding Document (NCP) must form part of all bids¹ invited.
- 2 Section 4 (1) (b) (iii) of the Competition Act No. 89 of 1998, as amended, prohibits an agreement between, or concerted practice by, firms, or a decision by an association of firms, if it is between parties in a horizontal relationship and if it involves collusive bidding (or bid rigging).² Collusive bidding is a pe se prohibition meaning that it cannot be justified under any grounds.
- 3 Treasury Regulation 16A9 prescribes that accounting officers and accounting authorities must take all reasonable steps to prevent abuse of the supply chain management system and authorizes accounting officers and accounting authorities to:
 - a. disregard the bid of any bidder if that bidder, or any of its directors have abused the institution's supply chain management system and or committed fraud or any other improper conduct in relation to such system.
 - b. cancel a contract awarded to a supplier of goods and services if the supplier committed any corrupt or fraudulent act during the bidding process or the execution of that contract.
- 4 This NCP serves as a certificate of declaration that would be used by institutions to ensure that, when bids are considered, reasonable steps are taken to prevent any form of bid-rigging.
- 5 In order to give effect to the above, the attached Certificate of Bid Determination (NCP 9) must be completed and submitted with the bid:

¹ Includes price quotations, advertised competitive bids, limited bids and proposals.

² Bid rigging (or collusive bidding) occurs when businesses, that would otherwise be expected to compete, secretly conspire to raise prices or lower the quality of goods and / or services for purchasers who wish to acquire goods and / or services through a bidding process. Bid rigging is, therefore, an agreement between competitors not to compete.

CERTIFICATE OF INDEPENDENT BID DETERMINATION

I, the undersigned, in submitting the accompanying bid:
Labour for the Construction Handling Facility Occidental JRanch
NC/DALQ/1973

in response to the invitation for the bid made by:
Department of Agriculture Land Reform and Rural Development
do hereby make the following statements that I certify to be true and complete in every respect:

I certify, on behalf of: _____ that:
(Name of Bidder)

- 1 I have read and I understand the contents of this Certificate;
- 2 I understand that the accompanying bid will be disqualified if this Certificate is found not to be true and complete in every respect;
- 3 I am authorized by the bidder to sign this Certificate, and to submit the accompanying bid, on behalf of the bidder;
- 4 Each person whose signature appears on the accompanying bid has been authorized by the bidder to determine the terms of, and to sign the bid, on behalf of the bidder;
- 5 For the purposes of this Certificate and the accompanying bid, I understand that the word "competitor" shall include any individual or organization, other than the bidder, whether or not affiliated with the bidder, who:
 - (a) has been requested to submit a bid in response to this bid invitation;
 - (b) could potentially submit a bid in response to this bid invitation, based on their qualifications, abilities or experience; and
 - (c) provides the same goods and services as the bidder and/or is in the same line of business as the bidder
- 6 The bidder has arrived at the accompanying bid independently from, and without consultation, communication, agreement or arrangement with any competitor. However communication between partners in a joint venture or consortium³ will not be construed as collusive bidding.
- 7 In particular, without limiting the generality of paragraphs 6 above, there has been no consultation, communication, agreement or arrangement with any competitor regarding:
 - a) prices;
 - b) geographical area where product or service will be rendered (market allocation)
 - c) methods, factors or formulas used to calculate prices;
 - d) the intention or decision to submit or not to submit, a bid;
 - e) the submission of a bid which does not meet the specifications and conditions of the bid; or
 - f) bidding with the intention not to win the bid.
- 8 In addition, there have been no consultations, communications, agreements or arrangements with any competitor regarding the quality, quantity, specifications and conditions or delivery particulars of the products or services to which this bid invitation relates.
- 9 The terms of the accompanying bid have not been, and will not be, disclosed by the bidder, directly or indirectly, to any competitor, prior to the date and time of the official bid opening or of the awarding of the contract.

10 I am aware that, in addition and without prejudice to any other remedy provided to combat any restrictive practices related to bids and contracts, bids that are suspicious will be reported to the Competition Commission for investigation and possible imposition of administrative penalties in terms of section 59 of the Competition Act No 89 of 1998 and or may be reported to the National Prosecuting Authority (NPA) for criminal investigation and or may be restricted from conducting business with the public sector for a period not exceeding ten (10) years in terms of the Prevention and Combating of Corrupt Activities Act No 12 of 2004 or any other applicable legislation.

.....
Signature

.....
Date

.....
Position

.....
Name of Bidder

³ Joint venture or Consortium means an association of persons for the purpose of combining their expertise, property, capital, efforts, skill and knowledge in an activity for the execution of a contract.

GOVERNMENT PROCUREMENT

GENERAL CONDITIONS OF CONTRACT

July 2010

NOTES

The purpose of this document is to:

Draw special attention to certain general conditions applicable to government bids, contracts and orders; and To ensure that clients be familiar with regard to the rights and obligations of all parties involved in doing business with government.

In this document words in the singular also mean in the plural and vice versa and words in the masculine also mean in the feminine and neuter.

The General Conditions of Contract will form part of all bid documents and may not be amended.

Special Conditions of Contract (SCC) relevant to a specific bid, should be compiled separately for every bid (if applicable) and will supplement the General Conditions of Contract. Whenever there is a conflict, the provisions in the SCC shall prevail.

TABLE OF CLAUSES

- 1) Definitions
- 2) Application
- 3) General
- 4) Standards
- 5) Use of contract documents and information; inspection
- 6) Patent rights
- 7) Performance security
- 8) Inspections, tests and analysis
- 9) Packing
- 10) Delivery and documents
- 11) Insurance
- 12) Transportation
- 13) Incidental services
- 14) Spare parts
- 15) Warranty
- 16) Payment
- 17) Prices
- 18) Contract amendments
- 19) Assignment
- 20) Subcontracts
- 21) Delays in the supplier's performance
- 22) Penalties
- 23) Termination for default
- 24) Dumping and countervailing duties
- 25) Force Majeure
- 26) Termination for insolvency
- 27) Settlement of disputes
- 28) Limitation of liability
- 29) Governing language
- 30) Applicable law
- 31) Notices
- 32) Taxes and duties
- 33) National Industrial Participation Programme (NIPP)
- 34) Prohibition of restrictive practices

General Conditions of Contract

1. Definitions

1. The following terms shall be interpreted as indicated:
 - 1.1 "Closing time" means the date and hour specified in the bidding documents for the receipt of bids.
 - 1.2 "Contract" means the written agreement entered into between the purchaser and the supplier, as recorded in the contract form signed by the parties, including all attachments and appendices thereto and all documents incorporated by reference therein.
 - 1.3 "Contract price" means the price payable to the supplier under the contract for the full and proper performance of his contractual obligations.
 - 1.4 "Corrupt practice" means the offering, giving, receiving, or soliciting of any thing of value to influence the action of a public official in the procurement process or in contract execution.
 - 1.5 "Countervailing duties" are imposed in cases where an enterprise abroad is subsidized by its government and encouraged to market its products internationally.
 - 1.6 "Country of origin" means the place where the goods were mined, grown or produced or from which the services are supplied. Goods are produced when, through manufacturing, processing or substantial and major assembly of components, a commercially recognized new product results that is substantially different in basic characteristics or in purpose or utility from its components.
 - 1.7 "Day" means calendar day.
 - 1.8 "Delivery" means delivery in compliance of the conditions of the contract or order.
 - 1.9 "Delivery ex stock" means immediate delivery directly from stock actually on hand.
 - 1.10 "Delivery into consignees store or to his site" means delivered and unloaded in the specified store or depot or on the specified site in compliance with the conditions of the contract or order, the supplier bearing all risks and charges involved until the supplies are so delivered and a valid receipt is obtained.
 - 1.11 "Dumping" occurs when a private enterprise abroad market its goods on own initiative in the RSA at lower prices than that of the country of origin and which have the potential to harm the local industries in the RSA.
 - 1.12 "Force majeure" means an event beyond the control of the supplier and not involving the supplier's fault or negligence and not foreseeable. Such events may include, but is not restricted to, acts of the purchaser in its sovereign capacity, wars or revolutions, fires, floods, epidemics, quarantine restrictions and freight embargoes.
 - 1.13 "Fraudulent practice" means a misrepresentation of facts in order to influence a procurement process or the execution of a contract to the

detriment of any bidder, and includes collusive practice among bidders (prior to or after bid submission) designed to establish bid prices at artificial non-competitive levels and to deprive the bidder of the benefits of free and open competition.

- 1.14 "GCC" means the General Conditions of Contract.
- 1.15 "Goods" means all of the equipment, machinery, and/or other materials that the supplier is required to supply to the purchaser under the contract.
- 1.16 "Imported content" means that portion of the bidding price represented by the cost of components, parts or materials which have been or are still to be imported (whether by the supplier or his subcontractors) and which costs are inclusive of the costs abroad, plus freight and other direct importation costs such as landing costs, dock dues, import duty, sales duty or other similar tax or duty at the South African place of entry as well as transportation and handling charges to the factory in the Republic where the supplies covered by the bid will be manufactured.
- 1.17 "Local content" means that portion of the bidding price which is not included in the imported content provided that local manufacture does take place.
- 1.18 "Manufacture" means the production of products in a factory using labour, materials, components and machinery and includes other related value-adding activities.
- 1.19 "Order" means an official written order issued for the supply of goods or works or the rendering of a service.
- 1.20 "Project site," where applicable, means the place indicated in bidding documents.
- 1.21 "Purchaser" means the organization purchasing the goods.
- 1.22 "Republic" means the Republic of South Africa.
- 1.23 "SCC" means the Special Conditions of Contract.
- 1.24 "Services" means those functional services ancillary to the supply of the goods, such as transportation and any other incidental services, such as installation, commissioning, provision of technical assistance, training, catering, gardening, security, maintenance and other such obligations of the supplier covered under the contract.
- 1.25 "Written" or "in writing" means handwritten in ink or any form of electronic or mechanical writing.

2. Application

- 2.1 These general conditions are applicable to all bids, contracts and orders including bids for functional and professional services, sales, hiring, letting and the granting or acquiring of rights, but excluding immovable property, unless otherwise indicated in the bidding documents.
- 2.2 Where applicable, special conditions of contract are also laid down to cover specific supplies, services or works.
- 2.3 Where such special conditions of contract are in conflict with these general conditions, the special conditions shall apply.

- 3. General**
- 3.1 Unless otherwise indicated in the bidding documents, the purchaser shall not be liable for any expense incurred in the preparation and submission of a bid. Where applicable a non-refundable fee for documents may be charged.
- 3.2 With certain exceptions, invitations to bid are only published in the Government Tender Bulletin. The Government Tender Bulletin may be obtained directly from the Government Printer, Private Bag X85, Pretoria 0001, or accessed electronically from www.treasury.gov.za
- 4. Standards**
- 4.1 The goods supplied shall conform to the standards mentioned in the bidding documents and specifications.
- 5 Use of contract documents and information; inspection.**
- 5.1 The supplier shall not, without the purchaser's prior written consent, disclose the contract, or any provision thereof, or any specification, plan, drawing, pattern, sample, or information furnished by or on behalf of the purchaser in connection therewith, to any person other than a person employed by the supplier in the performance of the contract. Disclosure to any such employed person shall be made in confidence and shall extend only so far as may be necessary for purposes of such performance.
- 5.2 The supplier shall not, without the purchaser's prior written consent, make use of any document or information mentioned in GCC clause 5.1 except for purposes of performing the contract.
- 5.3 Any document, other than the contract itself mentioned in GCC clause 5.1 shall remain the property of the purchaser and shall be returned (all copies) to the purchaser on completion of the supplier's performance under the contract if so required by the purchaser.
- 5.4 The supplier shall permit the purchaser to inspect the supplier's records relating to the performance of the supplier and to have them audited by auditors appointed by the purchaser, if so required by the purchaser.
- 6. Patent rights**
- 6.1 The supplier shall indemnify the purchaser against all third-party claims of infringement of patent, trademark, or industrial design rights arising from use of the goods or any part thereof by the purchaser.
- 7. Performance security**
- 7.1 Within thirty (30) days of receipt of the notification of contract award, the successful bidder shall furnish to the purchaser the performance security of the amount specified in SCC.
- 7.2 The proceeds of the performance security shall be payable to the purchaser as compensation for any loss resulting from the supplier's failure to complete his obligations under the contract.
- 7.3 The performance security shall be denominated in the currency of the contract, or in a freely convertible currency acceptable to the purchaser and shall be in one of the following forms:
- (a) a bank guarantee or an irrevocable letter of credit issued by a reputable bank located in the purchaser's country or abroad, acceptable to the purchaser, in the form provided in the bidding documents or another form acceptable to the purchaser; or
 - (b) a cashier's or certified cheque
- 7.4 The performance security will be discharged by the purchaser and returned to the supplier not later than thirty (30) days following the date

- of completion of the supplier's performance obligations under the contract, including any warranty obligations, unless otherwise specified in SCC.
- 8. Inspections, tests and analyses**
- 8.1 All pre-bidding testing will be for the account of the bidder.
 - 8.2 If it is a bid condition that supplies to be produced or services to be rendered should at any stage during production or execution or on completion be subject to inspection, the premises of the bidder or contractor shall be open, at all reasonable hours, for inspection by a representative of the Department or an organization acting on behalf of the Department.
 - 8.3 If there are no inspection requirements indicated in the bidding documents and no mention is made in the contract, but during the contract period it is decided that inspections shall be carried out, the purchaser shall itself make the necessary arrangements, including payment arrangements with the testing authority concerned.
 - 8.4 If the inspections, tests and analyses referred to in clauses 8.2 and 8.3 show the supplies to be in accordance with the contract requirements, the cost of the inspections, tests and analyses shall be defrayed by the purchaser.
 - 8.5 Where the supplies or services referred to in clauses 8.2 and 8.3 do not comply with the contract requirements, irrespective of whether such supplies or services are accepted or not, the cost in connection with these inspections, tests or analyses shall be defrayed by the supplier.
 - 8.6 Supplies and services which are referred to in clauses 8.2 and 8.3 and which do not comply with the contract requirements may be rejected.
 - 8.7 Any contract supplies may on or after delivery be inspected, tested or analyzed and may be rejected if found not to comply with the requirements of the contract. Such rejected supplies shall be held at the cost and risk of the supplier who shall, when called upon, remove them immediately at his own cost and forthwith substitute them with supplies which do comply with the requirements of the contract. Failing such removal the rejected supplies shall be returned at the suppliers cost and risk. Should the supplier fail to provide the substitute supplies forthwith, the purchaser may, without giving the supplier further opportunity to substitute the rejected supplies, purchase such supplies as may be necessary at the expense of the supplier.
 - 8.8 The provisions of clauses 8.4 to 8.7 shall not prejudice the right of the purchaser to cancel the contract on account of a breach of the conditions thereof, or to act in terms of Clause 23 of GCC.
- 9. Packing**
- 9.1 The supplier shall provide such packing of the goods as is required to prevent their damage or deterioration during transit to their final destination, as indicated in the contract. The packing shall be sufficient to withstand, without limitation, rough handling during transit and exposure to extreme temperatures, salt and precipitation during transit, and open storage. Packing, case size and weights shall take into consideration, where appropriate, the remoteness of the goods' final destination and the absence of heavy handling facilities at all points in transit.
 - 9.2 The packing, marking, and documentation within and outside the packages shall comply strictly with such special requirements as shall be expressly provided for in the contract, including additional

requirements, if any, specified in SCC, and in any subsequent instructions ordered by the purchaser.

- 10. Delivery and documents**
- 10.1 Delivery of the goods shall be made by the supplier in accordance with the terms specified in the contract. The details of shipping and/or other documents to be furnished by the supplier are specified in SCC.
- 10.2 Documents to be submitted by the supplier are specified in SCC.
- 11. Insurance**
- 11.1 The goods supplied under the contract shall be fully insured in a freely convertible currency against loss or damage incidental to manufacture or acquisition, transportation, storage and delivery in the manner specified in the SCC.
- 12. Transportation**
- 12.1 Should a price other than an all-inclusive delivered price be required, this shall be specified in the SCC.
- 13. Incidental services**
- 13.1 The supplier may be required to provide any or all of the following services, including additional services, if any, specified in SCC:
- (a) performance or supervision of on-site assembly and/or commissioning of the supplied goods;
 - (b) furnishing of tools required for assembly and/or maintenance of the supplied goods;
 - (c) furnishing of a detailed operations and maintenance manual for each appropriate unit of the supplied goods;
 - (d) performance or supervision or maintenance and/or repair of the supplied goods, for a period of time agreed by the parties, provided that this service shall not relieve the supplier of any warranty obligations under this contract; and
 - (e) training of the purchaser's personnel, at the supplier's plant and/or on-site, in assembly, start-up, operation, maintenance, and/or repair of the supplied goods.
- 13.2 Prices charged by the supplier for incidental services, if not included in the contract price for the goods, shall be agreed upon in advance by the parties and shall not exceed the prevailing rates charged to other parties by the supplier for similar services.
- 14. Spare parts**
- 14.1 As specified in SCC, the supplier may be required to provide any or all of the following materials, notifications, and information pertaining to spare parts manufactured or distributed by the supplier:
- (a) such spare parts as the purchaser may elect to purchase from the supplier, provided that this election shall not relieve the supplier of any warranty obligations under the contract; and
 - (b) in the event of termination of production of the spare parts:
 - (i) Advance notification to the purchaser of the pending termination, in sufficient time to permit the purchaser to procure needed requirements; and
 - (ii) following such termination, furnishing at no cost to the purchaser, the blueprints, drawings, and specifications of the spare parts, if requested.
- 15. Warranty**
- 15.1 The supplier warrants that the goods supplied under the contract are new, unused, of the most recent or current models, and that they incorporate all recent improvements in design and materials unless provided otherwise in the contract. The supplier further warrants that all goods supplied under this contract shall have no defect, arising from design, materials, or workmanship (except when the design and/or material is required by the purchaser's specifications) or from any act or omission of the supplier, that may develop under normal use of the

supplied goods in the conditions prevailing in the country of final destination.

- 15.2 This warranty shall remain valid for twelve (12) months after the goods, or any portion thereof as the case may be, have been delivered to and accepted at the final destination indicated in the contract, or for eighteen (18) months after the date of shipment from the port or place of loading in the source country, whichever period concludes earlier, unless specified otherwise in SCC.
- 15.3 The purchaser shall promptly notify the supplier in writing of any claims arising under this warranty.
- 15.4 Upon receipt of such notice, the supplier shall, within the period specified in SCC and with all reasonable speed, repair or replace the defective goods or parts thereof, without costs to the purchaser.
- 15.5 If the supplier, having been notified, fails to remedy the defect(s) within the period specified in SCC, the purchaser may proceed to take such remedial action as may be necessary, at the supplier's risk and expense and without prejudice to any other rights which the purchaser may have against the supplier under the contract.

16. Payment

- 16.1 The method and conditions of payment to be made to the supplier under this contract shall be specified in SCC.
- 16.2 The supplier shall furnish the purchaser with an invoice accompanied by a copy of the delivery note and upon fulfillment of other obligations stipulated in the contract.
- 16.3 Payments shall be made promptly by the purchaser, but in no case later than thirty (30) days after submission of an invoice or claim by the supplier.
- 16.4 Payment will be made in Rand unless otherwise stipulated in SCC.

17. Prices

- 17.1 Prices charged by the supplier for goods delivered and services performed under the contract shall not vary from the prices quoted by the supplier in his bid, with the exception of any price adjustments authorized in SCC or in the purchaser's request for bid validity extension, as the case may be.

18. Contract amendments

- 18.1 No variation in or modification of the terms of the contract shall be made except by written amendment signed by the parties concerned.

19. Assignment

- 19.1 The supplier shall not assign, in whole or in part, its obligations to perform under the contract, except with the purchaser's prior written consent.

20. Subcontracts

- 20.1 The supplier shall notify the purchaser in writing of all subcontracts awarded under this contracts if not already specified in the bid. Such notification, in the original bid or later, shall not relieve the supplier from any liability or obligation under the contract.

21. Delays in the supplier's performance

- 21.1 Delivery of the goods and performance of services shall be made by the supplier in accordance with the time schedule prescribed by the purchaser in the contract.
- 21.2 If at any time during performance of the contract, the supplier or its subcontractor(s) should encounter conditions impeding timely delivery of the goods and performance of services, the supplier shall promptly

notify the purchaser in writing of the fact of the delay, its likely duration and its cause(s). As soon as practicable after receipt of the supplier's notice, the purchaser shall evaluate the situation and may at his discretion extend the supplier's time for performance, with or without the imposition of penalties, in which case the extension shall be ratified by the parties by amendment of contract.

- 21.3 No provision in a contract shall be deemed to prohibit the obtaining of supplies or services from a national department, provincial department, or a local authority.
- 21.4 The right is reserved to procure outside of the contract small quantities or to have minor essential services executed if an emergency arises, the supplier's point of supply is not situated at or near the place where the supplies are required, or the supplier's services are not readily available.
- 21.5 Except as provided under GCC Clause 25, a delay by the supplier in the performance of its delivery obligations shall render the supplier liable to the imposition of penalties, pursuant to GCC Clause 22, unless an extension of time is agreed upon pursuant to GCC Clause without the application of penalties.
- 21.6 Upon any delay beyond the delivery period in the case of a supplies contract, the purchaser shall, without canceling the contract, be entitled to purchase supplies of a similar quality and up to the same quantity in substitution of the goods not supplied in conformity with the contract and to return any goods delivered later at the supplier's expense and risk, or to cancel the contract and buy such goods as may be required to complete the contract and without prejudice to his other rights, be entitled to claim damages from the supplier.

22. Penalties

- 22.1 Subject to GCC Clause 25, if the supplier fails to deliver any or all of the goods or to perform the services within the period(s) specified in the contract, the purchaser shall, without prejudice to its other remedies under the contract, deduct from the contract price, as a penalty, a sum calculated on the delivered price of the delayed goods or unperformed services using the current prime interest rate calculated for each day of the delay until actual delivery or performance. The purchaser may also consider termination of the contract pursuant to GCC Clause 23.

23. Termination for default

- 23.1 The purchaser, without prejudice to any other remedy for breach of contract, by written notice of default sent to the supplier, may terminate this contract in whole or in part:
- (a) if the supplier fails to deliver any or all of the goods within the period(s) specified in the contract, or within any extension thereof granted by the purchaser pursuant to GCC Clause 21.2;
 - (b) if the Supplier fails to perform any other obligation(s) under the contract; or
 - (c) if the supplier, in the judgment of the purchaser, has engaged in corrupt or fraudulent practices in competing for or in executing the contract.
- 23.2 In the event the purchaser terminates the contract in whole or in part, the purchaser may procure, upon such terms and in such manner as it deems appropriate, goods, works or services similar to those undelivered, and the supplier shall be liable to the purchaser for any

excess costs for such similar goods, works or services. However, the supplier shall continue performance of the contract to the extent not terminated.

23.3 Where the purchaser terminates the contract in whole or in part, the purchaser may decide to impose a restriction penalty on the supplier by prohibiting such supplier from doing business with the public sector for a period not exceeding 10 years.

23.4 If a purchaser intends imposing a restriction on a supplier or any person associated with the supplier, the supplier will be allowed a time period of not more than fourteen (14) days to provide reasons why the envisaged restriction should not be imposed. Should the supplier fail to respond within the stipulated fourteen (14) days the purchaser may regard the intended penalty as not objected against and may impose it on the supplier.

23.5 Any restriction imposed on any person by the Accounting Officer / Authority will, at the discretion of the Accounting Officer / Authority, also be applicable to any other enterprise or any partner, manager, director or other person who wholly or partly exercises or exercised or may exercise control over the enterprise of the first-mentioned person, and with which enterprise or person the first-mentioned person, is or was in the opinion of the Accounting Officer / Authority actively associated.

23.6 If a restriction is imposed, the purchaser must, within five (5) working days of such imposition, furnish the National Treasury, with the following information:

1. the name and address of the supplier and / or person restricted by the purchaser;
2. the date of commencement of the restriction
3. the period of restriction; and
4. the reasons for the restriction.

These details will be loaded in the National Treasury's central database of suppliers or persons prohibited from doing business with the public sector.

23.7 If a court of law convicts a person of an offence as contemplated in sections 12 or 13 of the Prevention and Combating of Corrupt Activities Act, No. 12 of 2004, the court may also rule that such person's name be endorsed on the Register for Tender Defaulters. When a person's name has been endorsed on the Register, the person will be prohibited from doing business with the public sector for a period not less than five years and not more than 10 years. The National Treasury is empowered to determine the period of restriction and each case will be dealt with on its own merits. According to section 32 of the Act the Register must be open to the public. The Register can be perused on the National Treasury website.

24. Anti-dumping and countervailing duties and rights

24.1 anti- When, after the date of bid, provisional payments are required, or dumping or countervailing duties are imposed, or the amount of a provisional payment or anti-dumping or countervailing right is increased in respect of any dumped or subsidized import, the State is not liable for any amount so required or imposed, or for the amount of any such increase. When, after the said date, such a provisional payment is no longer required or any such anti-dumping or

countervailing right is abolished, or where the amount of such provisional payment or any such right is reduced, any such favourable difference shall on demand be paid forthwith by the contractor to the State or the State may deduct such amounts from moneys (if any) which may otherwise be due to the contractor in regard to supplies or services which he delivered or rendered, or is to deliver or render in terms of the contract or any other contract or any other amount which may be due to him

25. Force Majeure

25.1 Notwithstanding the provisions of GCC Clauses 22 and 23, the supplier shall not be liable for forfeiture of its performance security, damages, or termination for default if and to the extent that his delay in performance or other failure to perform his obligations under the contract is the result of an event of force majeure.

25.2 If a force majeure situation arises, the supplier shall promptly notify the purchaser in writing of such condition and the cause thereof. Unless otherwise directed by the purchaser in writing, the supplier shall continue to perform its obligations under the contract as far as is reasonably practical, and shall seek all reasonable alternative means for performance not prevented by the force majeure event.

26. Termination for insolvency

26.1 The purchaser may at any time terminate the contract by giving written notice to the supplier if the supplier becomes bankrupt or otherwise insolvent. In this event, termination will be without compensation to the supplier, provided that such termination will not prejudice or affect any right of action or remedy which has accrued or will accrue thereafter to the purchaser.

27. Settlement of Disputes

27.1 If any dispute or difference of any kind whatsoever arises between the purchaser and the supplier in connection with or arising out of the contract, the parties shall make every effort to resolve amicably such dispute or difference by mutual consultation.

27.2 If, after thirty (30) days, the parties have failed to resolve their dispute or difference by such mutual consultation, then either the purchaser or the supplier may give notice to the other party of his intention to commence with mediation. No mediation in respect of this matter may be commenced unless such notice is given to the other party.

27.3 Should it not be possible to settle a dispute by means of mediation, it may be settled in a South African court of law.

- o Mediation proceedings shall be conducted in accordance with the rules of procedure specified in the SCC.

27.5 Notwithstanding any reference to mediation and/or court proceedings herein,

- (a) the parties shall continue to perform their respective obligations under the contract unless they otherwise agree; and
- (b) the purchaser shall pay the supplier any monies due the supplier.

28. Limitation of liability

28.1 Except in cases of criminal negligence or willful misconduct, and in the case of infringement pursuant to Clause 6;

- (a) the supplier shall not be liable to the purchaser, whether in contract, tort, or otherwise, for any indirect or consequential loss or damage, loss of use, loss of production, or loss of profits or interest costs, provided that this exclusion shall not apply to any obligation of the supplier to pay penalties and/or damages to the purchaser; and

- (b) the aggregate liability of the supplier to the purchaser, whether under the contract, in tort or otherwise, shall not exceed the total contract price, provided that this limitation shall not apply to the cost of repairing or replacing defective equipment.

- 29. Governing language** 29.1 The contract shall be written in English. All correspondence and other documents pertaining to the contract that is exchanged by the parties shall also be written in English.
- 30. Applicable law** 30.1 The contract shall be interpreted in accordance with South African laws, unless otherwise specified in SCC.
- 31. Notices** (a) Ee
31.2 The time mentioned in the contract documents for performing any act after such aforesaid notice has been given, shall be reckoned from the date of posting of such notice.
- 32. Taxes and duties** 32.1 A foreign supplier shall be entirely responsible for all taxes, stamp duties, license fees, and other such levies imposed outside the purchaser's country.
32.2 A local supplier shall be entirely responsible for all taxes, duties, license fees, etc., incurred until delivery of the contracted goods to the purchaser.
32.3 No contract shall be concluded with any bidder whose tax matters are not in order. Prior to the award of a bid the Department must be in possession of a tax clearance certificate, submitted by the bidder. This certificate must be an original issued by the South African Revenue Services.
- 33. National Industrial Participation (NIP) Programme** 33.1 The NIP Programme administered by the Department of Trade and Industry shall be applicable to all contracts that are subject to the NIP obligation.
- 34 Prohibition of Restrictive practices** 34.1 In terms of section 4 (1) (b) (iii) of the Competition Act No. 89 of 1998, as amended, an agreement between, or concerted practice by, firms, or a decision by an association of firms, is prohibited if it is between parties in a horizontal relationship and if a bidder (s) is / are or a contractor(s) was / were involved in collusive bidding (or bid rigging).
34.2 If a bidder(s) or contractor(s), based on reasonable grounds or evidence obtained by the purchaser, has / have engaged in the restrictive practice referred to above, the purchaser may refer the matter to the Competition Commission for investigation and possible imposition of administrative penalties as contemplated in the Competition Act No. 89 of 1998.
34.3 If a bidder(s) or contractor(s), has / have been found guilty by the Competition Commission of the restrictive practice referred to above, the purchaser may, in addition and without prejudice to any other remedy provided for, invalidate the bid(s) for such item(s) offered, and / or terminate the contract in whole or part, and / or restrict the bidder(s) or contractor(s) from conducting business with the public sector for a period not exceeding ten (10) years and / or claim damages from the bidder(s) or contractor(s) concerned.



SPECIAL CONDITIONS

BID NUMBER: NC/DALQ/1973

PROJECT LEADER: Koos Jordaan

TELEPHONE NUMBER: 0834115482

PROJECT DESCRIPTION: Labour for the Construction Handling Facility Occidental |Ranch

1 REGULATORY FRAMEWORK

This bid and all contracts emanating there from will be subject to the general conditions of contract issued in accordance with Treasury Regulation 16A published in terms of Public Finance Management Act (PFMA), 1999 (Act 1 of 1999). The special conditions of contract are supplementary to that of the general conditions of contract. Where, however, the special conditions of contract are in conflict with General Conditions of Contract (GCC), the special conditions of contract prevail.

2 EVALUATION CRITERIA

- 2.1 In terms of regulation 6 of the Preferential Procurement Regulations 2011 pertaining to the Preferential Procurement Policy Framework Policy Act, 2000 (Act 5 of 2000), responsive bids will be adjudicated by the department on the 80/20 preference point system in terms of which points are awarded to bidders on the basis of: The bid price (maximum of 80 points) B-BBEE status level of contributor (maximum 20 points)
- 2.2 A maximum of 20 points may be allocated to a bidder for attaining its B-BBEE status level of contributor in accordance with the table below:

B-BBEE Status Level of Contributor	Number of points (80/20 system)
1	20
2	18
3	14
4	12
5	8
6	6
7	4
8	2
Non-compliant contributor	0

- 2.3 Bidders are required to complete the preference claim form (NCP 6.1), and submit their original and valid B-BBEE status level verification certificate/sworn affidavit or a certified copy thereof in order to claim the B-BBEE status level points.
- 2.4 The points scored by a bidder in respect of the level of B-BBEE contribution will be added to the points scored for price.
- 2.5 Only bidders who have completed and signed the declaration part of the preference claim form and who have submitted a B-BBEE status level certificate issued by a registered auditor, accounting officer (as contemplated in section 60 (4) of the Close Corporation Act, 1984 (Act no 69 of 1984) or an accredited verification agency will be considered for preference points.
- 2.6 The total points scored will be rounded off to the nearest 2 decimals.
- 2.7 In the event that two or more bids have scored equal total points, the contract will be awarded to the bidder scoring the highest number of points for B-BBEE status. Should two or more bids be equal in all respects, the award shall be decided by drawing of lots.
- 2.8 However, when functionality is part of the evaluation process and two or more bidders have scored equal points including equal preference points for B-BBEE, the contract will be awarded to the bidder scoring the highest for functionality.
- 2.9 A contract may, on reasonable and justifiable grounds, be awarded to a bidder that did not score the highest number in points.
- 2.10 A bidder must not be awarded points claimed for B-BBEE status level of contribution if it is indicated in the bid documents that such a bidder intends sub-contracting more than **25%** of the contract value to any other enterprise that does not qualify for at least the same number of points that the bidder qualifies for, unless the intended sub-contractor is an EME that has the capability and ability to execute the sub-contract.
- 2.11 The Department may, before the bid is adjudicated or at any time require a bidder to substantiate claims it has made with regard to preference.

3 SCOPE OF WORKS

The work entails Construction of Stock Handling facility

4 TAX CLEARANCE CERTIFICATE

- 4.1 An original and valid tax clearance certificate issued by the South African Revenue Services (SARS) certifying that the taxes of the bidder are in order must be submitted at the closing date and time, where consortium/joint venture/sub-contractor are involved each party to the association must submit a separate valid original tax clearance certificate.
- 4.2 Alternatively bidders must provide the Department with the tax compliance status PIN issued by SARS to enable Departmental officials to verify their tax status on the SARS website.
- 4.3 Bidder's tax status will be verified from the time of submitting a bid up until the last payment is made to the appointed supplier.
- 4.4 CSD REGISTRATION - Bidders must attach their proof of registration on the National Central Supplier database at the time of applicant or submission of a bid.

5 VALUE ADDED TAX

- 5.1 All bid prices must be inclusive of 15% value-added tax for all VAT vendors.
- 5.2 Failure to comply with this condition will invalidate the bid.

6 SUBMISSION OF BIDS

- 6.1 Bidders must submit the bid in hard copy format (paper document) to the department before the closing date (**22 February 2021**) and time (**11:00 AM**). The hard copy of the bid response will serve as the legal bid document and must be signed in ink. The bid must be addressed to:

DEPARTMENT OF AGRICULTURE, LAND REFORM AND RURAL DEVELOPMENT
162 GEORGE STREET
KIMBERLEY
8301

- 6.2 Each bid should be submitted in a separate, sealed envelope or suitable cover on which the name and address of the bidder, the bid number and the closing date must be clearly endorsed.

7 LATE BIDS

Bids received after the closing date and time, at the address indicated in the bid documents, will not be accepted for consideration and where applicable, be returned unopened to the bidder.

8 CONTRACT PERIOD

The work must be completed within **45 days** after the purchase order is issued.

9 COUNTER CONDITIONS

Bidders' attention is drawn to the fact that amendments to any of the bid document conditions or setting of counter conditions by bidders may result in the invalidation of such bids.

10 ALTERNATIVE TENDERS

It is the Tenderer's option to deviate from the specification and present his own alternative. Provided that the Tenderer's Main Offer is according to specification and is acceptable to the Department in all respects, his alternative offer may also be considered for the purposes of awarding the contract. The alternative tender conditions or any deviation from the specification together with the quantified saving or additional expenses should be clearly indicated on such tender.

11 DEVIATION OF SPECIFICATIONS

In case of any proposed changes of specifications and agreed on by all bidders and the engineer during the site meeting, the changes will be recorded in the minutes of the meeting and be submitted to every bidder present at the site meeting by means of applicable communication systems. Any changes that may arise during the site meeting, will form part of the contract.

12 FRONTING

- 12.1 The department supports the spirit of Broad Based Black Economic Empowerment (BBBEE) and recognizes that real empowerment can only be achieved through individuals and businesses conducting themselves in accordance with the constitution and in an honest, fair, equitable, transparent and legally compliant manner against this background the department condemns any form of fronting.

12.2 The Department, in ensuring that bidders conduct themselves in an honest manner will, as part of the bid evaluation processes, conduct or initiate the necessary enquiries/investigations to determine the accuracy of the representation made in bid documents. should any of the fronting indicators as contained in the guidelines on complex structures and transactions and fronting, issued by the department of trade and industry, be established during such enquiry/investigation, the onus will be on the bidder / contractor to prove that fronting does not exist. Failure to do so within a period of 14 days from date of notification may invalidate the bid / contract and may also result in the restriction of the bidder/contractor to conduct business with the public sector for a period not exceeding ten (10) years, in addition to any other remedies the Department may have against the bidder/contractor concerned.

13 SUPPLIER DUE DILIGENCE

The Department reserves the right to conduct supplier due diligence prior to final award of the contract or at any time during the contract period. This may include site visits.

14 COMMUNICATION

- 14.1 Supply Chain Management (SCM) may communicate with bidders where clarity is sought after the closing date of the bid and prior to the award of the contract, or to extend the validity period of the bid, if necessary.
- 14.2 Any communication to any government official or a person acting in an advisory capacity for the state in respect of this bid between the closing date and the award of the bid by the bidder is discouraged.
- 14.3 All communication between the bidder and the Supply Chain Management (SCM) must be done in writing (on company's letterhead).

15 SPECIAL NOTE TO TENDERERS- EPWP

Bidders must take into account all the principles of the RDP, EPWP, the Government's policies on job creation as well as the problems they may encounter with the community organisations in the particular area before submitting their bids as no claims in this regard will be considered.

16 BILL OF QUANTITIES

Bidders are requested to check the Bill of Quantities and if any page is missing or duplicated, or if any figure or text is illegible or if any uncertainty or doubt exists as to the meaning of any description, or if these Bills of Quantities contains any obvious error, Bidders must notify The Department immediately to obtain the necessary rectification or explanation. No liability whatsoever with regards to the quoted amount will be recognized as a result of the aforementioned.

The Bill of Quantities is not meant for ordering any materials. Any orders based on the Bill of Quantities is at the Contractor's own risk.

17 METHOD OF MEASUREMENT

These Bills of Quantities were compiled in accordance with the method and guidance as set out in the sixth edition of the Standard System of Measuring Builder's Work and/or any amendments thereof. Where applicable the civil engineering work is measured in accordance to the method and guidelines as set out in the SABS 1200 specification.

18 SPECIFIED MATERIAL

SABS approval on goods are required (where applicable).

19 COMPLIANCE CERTIFICATE

Only the successful bidder to supply COMPLIANCE certificate for electrical work of the whole project.

20 GUARANTEE

Guarantee period to be 12 months for work done.

21 WATER

Tenderer must make provision in his tender for the provisioning of water, make arrangements for connection(s), necessary temporary plumbing and removal after completion and carry all relevant costs himself. The Department will not accept any responsibility for these temporary arrangements.

22 ELECTRICITY AND LIGHTING

Tenderer must make provisions in his tender for the provision of electricity, make arrangements for connection(s), necessary temporary connection, etc. and remove after completion and carry all relevant costs himself. The Department will not accept any responsibility for these temporary arrangements.

23 OCCUPATIONAL HEALTH & SAFETY ACT (85/1993)

It is required of tenderers to comply with the Occupational Health and Safety Act 1993 and the Constructions Regulations 2003. Occupational Health and Safety Act, (Act 85 of 1993), the Construction Regulations 2003 published in the Government Gazette No. 25207 dated 18 July 2003.

The Act and Regulations can be obtained from:
Northern Cape Provincial Communication Officer
Gaolathle Sefothlo
Tel: 053 838 1500 / Fax: 053 832 4798
Email: gaolathle.sefothlo@labour.gov.za

Bidders shall comply with all aspects of the Act and Regulations mentioned above. The following items have been identified by the client as possible hazard areas (Health and Safety Specification in terms of Clause 4.(1) (a)) and shall specifically be included in the "Health and Safety Plan" as described in clause 5.(1) of the Regulations:

1. Fall protection
2. Excavations
3. Demolition work
4. Scaffolding
5. Material hoists
6. Construction vehicles and mobile plant
7. Electrical installations and machinery on construction sites
8. Temporary storage of flammable liquids on construction sites
9. Housekeeping on construction sites
10. Stacking and storage on construction sites

24 LOCAL LABOUR

Service provider to make use of local subcontractors as well as skilled and unskilled local labor if possible. 80% of the workforce employed by the contractor for non-specialized work must be from the local community. The successful bidder must submit signed time sheets monthly as proof for EPWP records. Where applicable.

25 PENALTIES

A penalty fee of 0.0% of the total contract amount will be charged per day if the work is not completed within the stipulated time frame.

26 OTHER CONDITIONS

- 26.1 If one member of the company is employed by the state, it is a bidder's responsibility to provide the department with an approval documents from their employer's executing authority.
- 26.2 Recent (not older than 3 months) proof of company's address or confirmation from the municipality should be attached. Failure to submit proof of company's address may invalidate your bid.
- 26.3 Bidders must submit copies of identity documents of all directors or shareholders of the company with bid documents at the closing date and time of the bid and failure to do so the bid may not be considered.
- 26.4 The departmental project official/leader must be contacted 1 week prior to delivery.
- 26.5 The use of correction fluid or correction tape and scratching without initialling on bid documents will invalidate your bid.
- 26.6 All items listed on the departmental bill of quantities should be priced or billed for and the total bid price should be transferred to page 2. Inconsistency between the totals will invalidate your bid.
- 26.7 Amending the bill of quantities will invalidate the bid. Clarity can be sought from the project leader for any information regarding the bid to gain a clear understanding of the works before completion and submission of the bid.
- 26.8 The Department reserves the right not to award the tender or accept the lowest tender or any bid.
- 26.9 The Department has a right to award the bid to more than one bidder if the need arises.
- 26.10 The Northern Cape Provincial Supply Chain Management Procurement Policy Framework, approved in December 2018, States that the Provincial Departments must at least spend 60% of their procurement budget on Designated Groups within the province. The Department Reserves the right to award contracts based on the above mentioned framework policy.
- 26.11 Latest proof of company registration from Companies Intellectual Property Commission (CIPC) must be submitted in the form of certified copies of the relevant registration.
- 26.12 In the case of a joint venture, all partners (members) must include their SARS certificates/SARS PIN, a joint venture BBBEE certificate and a joint venture agreement. Parties to a joint venture should complete the following documents separately:
 - NCP 4
 - NCP 8
 - NCP 9

- 26.13 After the satisfactory delivery of services, payment will be made within 30 days after acceptance and receiving of a valid original tax invoice.
- 26.14 Every bidder must make sure of the extent of work for the specific bid.
- 26.15 Bidders must complete the attached page, referring to relevant previous experience.
- 26.16 .The site on which the service will be delivered is at Occidental Ranch (200 km north from Kuruman)
- 26.17 A compulsory site meeting will be held on Occidental Ranch co-ordinates 26°35'41" S - 23°26'24" E
- 26.18 On completion of the stock handling facility, the facility must be tested by the contractor in the presence of the project leader and beneficiaries
- 26.22 The required CIDB grading for this bid is 1CE
- 26.23 Proof of Comprehensive insurance and health and safety registration at Dept of Labour is required before the contractor will be allowed to commence with work

DECLARATION FOR BID DOCUMENT: NC/DALQ/1973

I, the undersigned (name, surname & designation)

.....
Hereby accept the conditions stated above.

.....
Signature

.....
Date

Specifications of Contract

[General Specifications:

1. All concrete works must have a 28 day strength of 30Mpa;
2. SABS 1200 specifications for civil engineering construction apply
3. Only new steel and no used or reject steel are to be used.

]

BILL OF QUANTITIES

TESTING OF BOREHOLES

Item No	DESCRIPTION	QUANT.	COST/ITEM (Vat excl.)	TOTAL COST (Vat excl.)
1.	Preliminary & General			
1.1	Water and Electricity (to be established on site)	1	R	R
1.2	Housing facilities and Toilets (to be established on site)	1	R	R
1.3	Remove and clear all excess construction material and waist from total construction area utilized	1	R	R
1.4	Cost of comprehensive insurance for the contract period. This must include all risk, third party and political violence insurance.	1	R	R
1.5	Compliance to the OCCUPATIONAL HEALTH & SAFETY ACT (85/1993)	1	R -	R -
	TOTAL COST (Vat excl.)			R

HANDLING FACILITY

ITEM No. 2	FARM	DESCRIPTION	QUANTITY	COST
2.1	Occidental Ranch	Labour for the construction of Handling Facility work nr 149	1	R
Sub Total (Excl Vat)				R





SUMMARY

Testing of Boreholes

	QTY	DESCRIPTION	PRICE IN RAND CURRENCY
1	1	Preliminary & General	R
2	1	Labour for Construction of Handling Facility	R
Sub Total			R
15% vat			R
TOTAL (VAT INCLUSIVE)			R

Project Name: Commercialization of black producers
Funding: Casp 2021

For Employer:

Specification Committee	Name	Signature	Rank	Office	Date
Compiled:	JJ Jordaan		CT (SRM)	Mothibistadt	10/02/2021
Checked:	E Louw		CT (SRM)	Mothibistadt	10/02/2021
Checked:	J.P. Smit		H.N.I.	Upington	10/02/2021
Approved:	N. Toerien		BMT	Upington	10/2/21

Project Office	Name	Signature	Rank	Office	Date
Checked:					

For Contractor:

Signature(s)

Name(s)

Capacity

For the Tenderer

(Name and address or organisation)

Date

0.5m Auction Gate

- Notes:
1. Construction to be as per design.
 2. Concrete work must have a 28 day strength of 30Mpa.
 3. New steel and not reject or used steel to be used.
 4. The following codes of practice from the South African Bureau of standards will be enforced:
 - (a) Standardized Specifications for Civil Engineering Construction – SABS 1200
 - (b) Wiring Code – SABS 0142
 5. General Conditions of Contract for Civil Engineering Construction, Sixth edition (1990), or most recent, which is not issued with this design, will apply when you quote/tender for this design.
 6. The Loading ramp needs a concrete foundation under the bricks of 400 x 400 x 400mm.
 7. The placing of each structure must be done by a Departmental Representative.
 8. Each gate must be fitted to uprights with three Dropside hinges
 9. All Steel must be painted with 2 layers of Red Oxide paint
 10. Horizontal pipes must be fitted to the inside of the Uprights
 11. All uprights must be fitted with steel caps

Loading Ramp

The Gates marked with X is of custom size and should only be manufactured after the head clamp, weighing crate and uprights is installed

Auction Gate

Weighing Crate

Head Clamp

Higher Uprights with 12mm Round bar on inside

Crushpen

0.7m Auction Gate

Push Pen

3.0m Auction Gate

Sorting Pen

Plan Layout:

SUSTAINABLE RESOURCE MANAGEMENT

DEPARTMENT OF AGRICULTURE LAND REFORM & RURAL DEVELOPMENT

JOHN TAOLO GAETSEWE OFFICE

Drawn by: Geteken deur: J.J. Jordaan

Designed by: Ontwerp deur: J.J. Jordaan

Checked by: Nagesien deur: E. Louw

Approved: Goedgekeur:

Scale: Skaal: NVT

Ref. No.: Verw. Nr.:

Tel : 053 - 773 1982
Faks : 053 - 773 1800

Date: 2016/04/02
Datum:

Drawing No.: Tek. Nr.:

1 of 3

Small Scale CrushPen & Loading Ramp

10/2/21

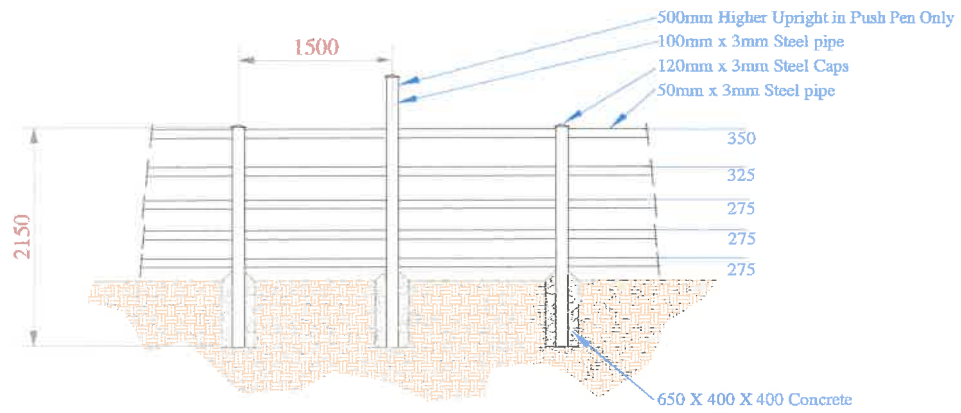

**FENCE FOR CRUSH PEN,
PUSH PEN & SORTING PEN**

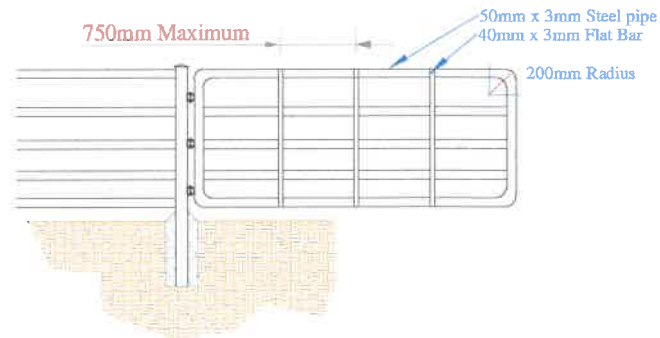

**DETAIL OF AUCTION GATE
I.R.O. WIDTHS SPECIFIED**

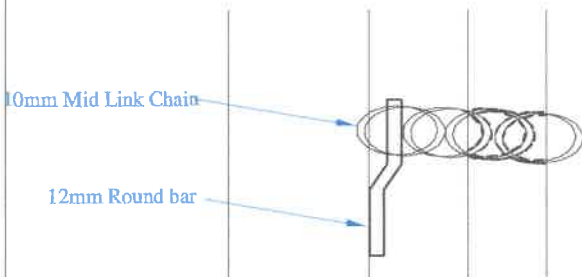

DETAIL OF CHAIN LINK FOR GATES

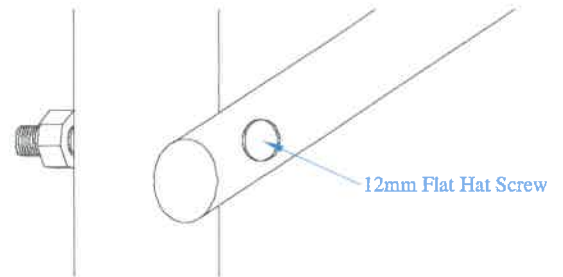

DETAIL OF FLAT HEAD SCREWS

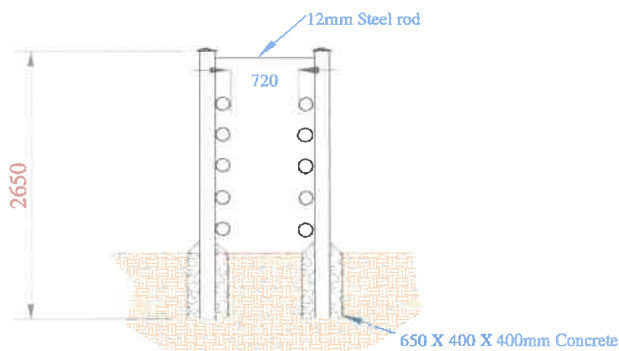

FRONT VIEW: PUSH PEN WITH HIGHER POST

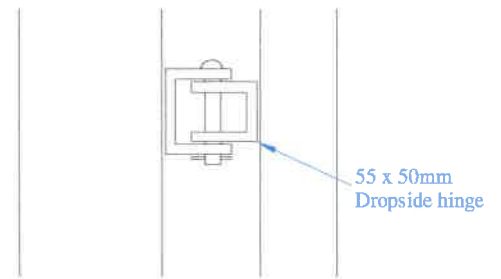

DETAIL OF DROPSIDE HINGE

SUSTAINABLE RESOURCE
MANAGEMENT

DEPARTMENT OF AGRICULTURE
LAND REFORM & RURAL DEVELOPMENT

JOHN TAOLO GAETSEWE
OFFICE

Drawn by:
Geteken deur: J.J. Jordaan

Designed by:
Ontwerp deur: J.J. Jordaan

Checked by:
Nagesien deur: E. Louw

Approved:
Goedgekeur:

Scale:
Skaal: NVT

Ref. No.:
Verw. Nr.:

Small Scale CrushPen & Loading Ramp

Tel : 053 - 773 1982
Faks : 053 - 773 1800

Date:
Datum: 2016/04/02

Drawing No.: Tek. Nr.:

2 of 3

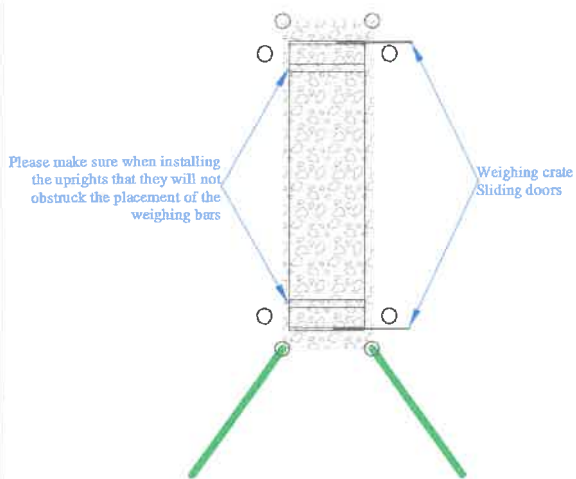

PLAN VIEW: WEIGHING CRATE

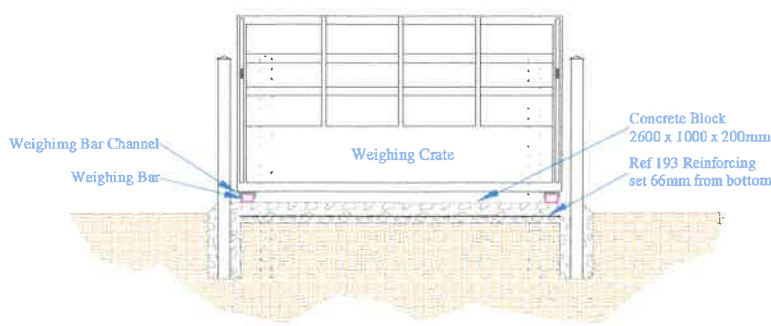

SIDE VIEW: WEIGHING CRATE

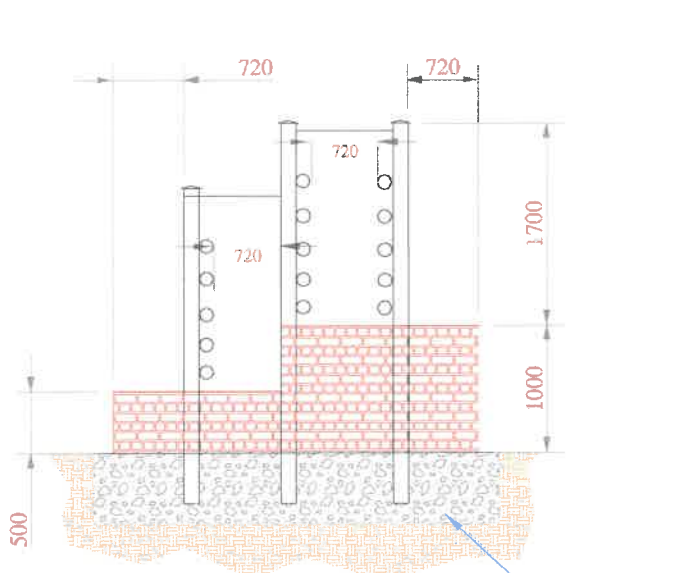

FRONT VIEW: LOADING RAMP

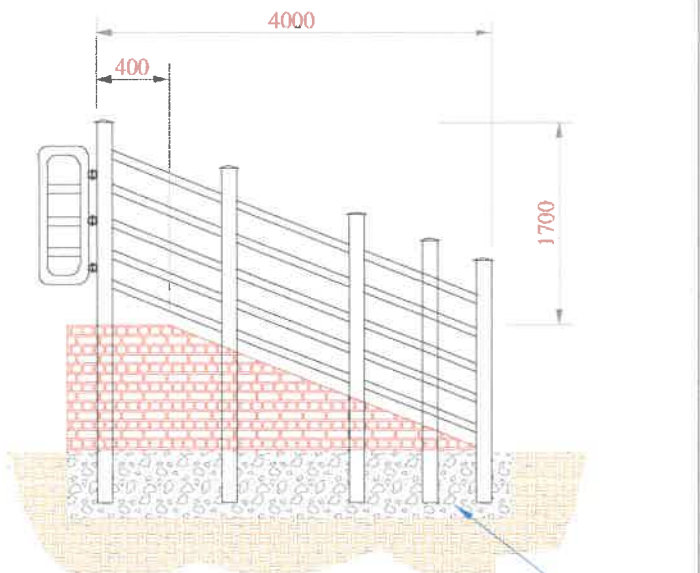

SIDE VIEW: LOADING RAMP

SUSTAINABLE RESOURCE MANAGEMENT		DEPARTMENT OF AGRICULTURE LAND REFORM & RURAL DEVELOPMENT		JOHN TAOLO GAETSEWE OFFICE	
Drawn by: Geteken deur: J.J. Jordaan		<h3>Small Scale CrushPen & Loading Ramp</h3>		Tel : 053 - 773 1982 Faks : 053 - 773 1800	
Designed by: Ontwerp deur: J.J. Jordaan				Date: Datum: 2016/04/02	
Checked by: Nagesien deur: E. Louw				Drawing No.: Tsk Nr.:	
Approved: Goedgekeur:		Scale: Skaal: NVT	Ref. No.: Verw. Nr.:	3 of 3	

Occidental Ranch 249

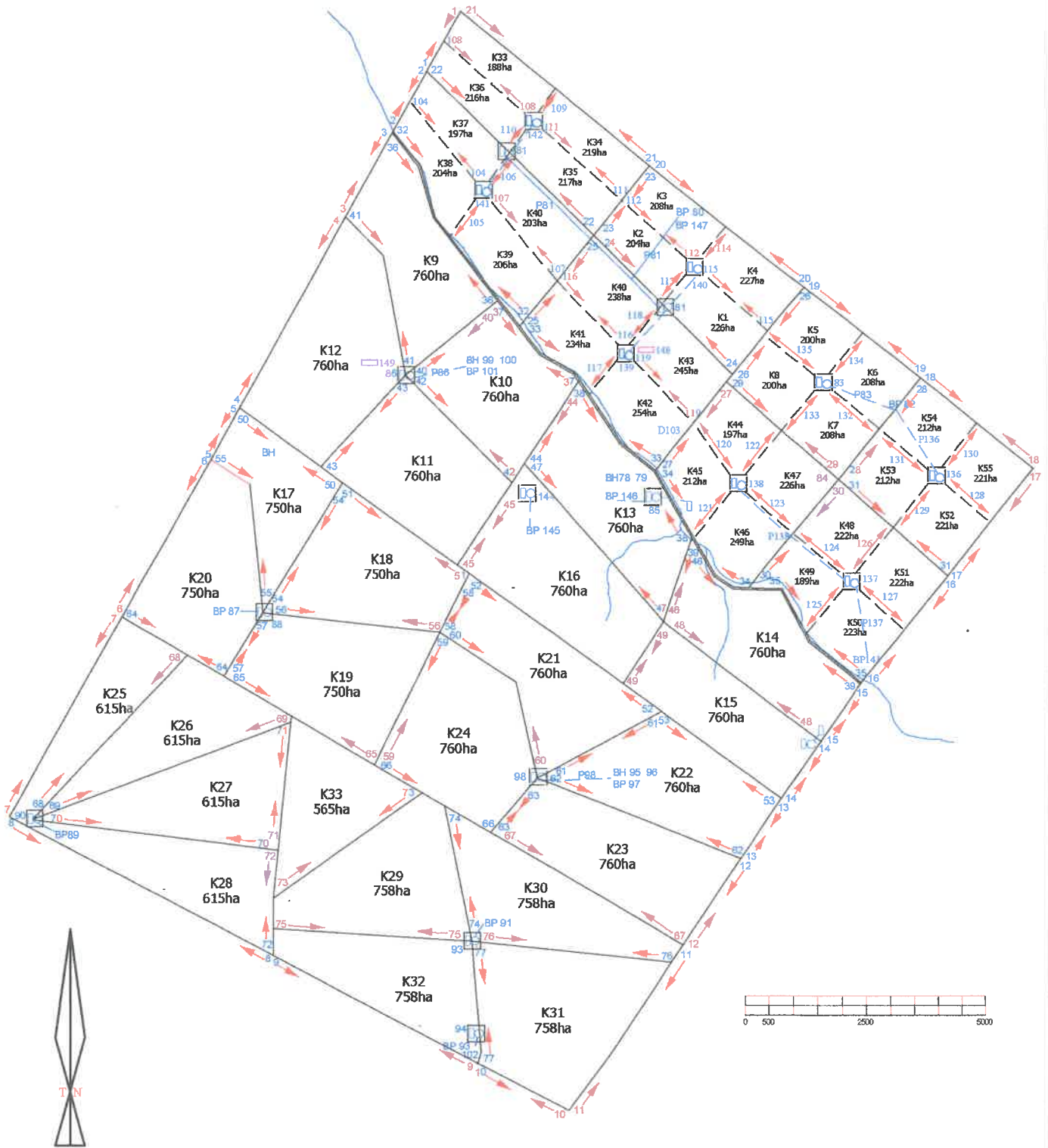

DEPARTMENT OF AGRICULTURE, LAND REFORM & RURAL DEVELOPMENT
NORTHERN CAPE PROVINCE

Drawn by: Geteken deur:	JJ Jordaan	Occidental Ranch 249	Tel: 053-773 1982
Designed by: Ontwerp deur:			Faks: 053-773 1800
Checked by: Nagesien deur:	E Louw	25077 ha	Date: 2019/09/09
Approved: Goedgekeur:		Scale: Skaal: 1:70,000	Ref. No.: Verw. Nr.: 5/Occidental Ranch 249

DEPARTEMENT VAN LANDBOU

BLW 23/12

Verwysing	Hoofkantoor Kimberley	Streek	JTG
Eienaar	RSA		
Plaaseenheid	Occidental Ranch 249		Landdrosdistrik Kuruman
Weidingskapasiteit van veld	15 ha/GVE	Getal vee wat op die veld aangehou mag word	1672 GVE

LYS VAN GRONDBEWARINGSWERKE VOLGENS PLAASKAART No. 5/Occidental Ranch 249 Bladsy: 1



* Indien subsidie verlang word, mag nie met die oprigting van die voorgestelde grondbewaringswerk begin word alvorens skriftelike toestemming daartoe van die Uitvoerende Beamppte ontvang is nie.

* Werke onder groep 1, is die voorgestelde grondbewaringswerke wat vir subsidie in aanmerking kan kom.

* Werke onder groep 2 is reeds gesubsidieer.

* Werke onder groep 3 word nie gesubsidieer nie.

Werk No. en Groep No.			Ligging volgens plaaskaart	Beskrywing en doel van werk	Afmettings
1	2	3			
	1		K33,K36	Border Fence	1430m
	2		K37,K38	Border Fence	1450m
	3		K9	Border Fence	2020m
	4		K12	Border Fence	4590m
	5		K17	Border Fence	1240m
	6		K20	Border Fence	3780m
	7		K25	Border Fence	4860m
	8		K28	Border Fence	6230m
	9		K32	Border Fence	4860m
	10		K31	Border Fence	2140m
	11		K31	Border Fence	4230m
	12		K23	Border Fence	2200m
	13		K22	Border Fence	1520m
	14		K15	Border Fence	1440m
	15		K14	Border Fence	1450m
	16		K50,K51	Border Fence	2870m
	17		K52,K55	Border Fence	2900m
	18		K54,K55	Border Fence	3060m
	19		K5,K6	Border Fence	3070m
	20		K3,K4	Border Fence	4120m
	21		K33,K34	Border Fence	5100m
	22		K35,K40/K36,K37	Camp Fence	4890m
	23		K2,K3/K34,K35	Camp Fence	1860m
	24		K2,K40/K1,K43	Camp Fence	4140m
	25		K39,K40/K40,K41	Camp Fence	2460m
	26		K1,K4/K5,K8	Camp Fence	2550m
	27		K42,K43/K44,K45	Camp Fence	2390m
	28		K6,K7/K53,K54	Camp Fence	2730m

Opgestel deur: JJ Jordaan		Rang Eng Tech	Kantoor Mothibistadt	Datum 09/9/2019
Nagesien en Goedgekeur deur: E Louw		Rang Control Tech	Kantoor Mothibistadt	Datum 09/9/2019

DEPARTEMENT VAN LANDBOU

Verwysing	Hoofkantoor Kimberley	Streek	JTG
Eienaar	RSA		
Plaaseenheid	Occidental Ranch 249	Landdrosdistrik	Kuruman
Weidingskapasiteit van veld	15 ha/GVE	Getal vee wat op die veld aangehou mag word	1672 GVE

LYS VAN GRONDBEWARINGSWERKE VOLGENS PLAASKAART No. 5/Occidental Ranch 249 Bladsy: 3

* Indien subsidie verlang word, mag nie met die oprigting van die voorgestelde grondbewaringswerk begin word alvorens skriftelike toestemming daartoe van die Uitvoerende Beampte ontvang is nie.

* Werke onder groep 1, is die voorgestelde grondbewaringswerke wat vir subsidie in aanmerking kan kom.

* Werke onder groep 2 is reeds gesubsidieer.

* Werke onder groep 3 word nie gesubsidieer nie.

Werk No. en Groep No.			Ligging volgens plaaskaart	Beskrywing en doel van werk	Afmetings
1	2	3			
	57		K19/20	Camp Fence	1560m
	58		K18/21	Camp Fence	1340m
	59		K19/24	Camp Fence	3100m
	60		K21/24	Camp Fence	3950m
	61		K21/22	Camp Fence	2970m
	62		K22/23	Camp Fence	4610m
	63		K23/24	Camp Fence	1490m
	64		K20/25,26	Camp Fence	2470m
	65		K19/26,33	Camp Fence	3690m
	66		K24/29,30,33	Camp Fence	2810m
	67		K23/30	Camp Fence	4690m
	68		K25/26	Camp Fence	4720m
	69		K26/27	Camp Fence	5760m
	70		K27/28	Camp Fence	5160m
	71		K27/33	Camp Fence	2820m
	72		K28/29,32,33	Camp Fence	2210m
	73		K29/33	Camp Fence	3840m
	74		K29/30	Camp Fence	2895m
	75		K29/32	Camp Fence	4170m
	76		K30/31	Camp Fence	4210m
	77		K31/32	Camp Fence	2610m
78			K13	Drilling Borehole	
79			K13	Testing Borehole	
	80		K2	Borehole pump	
	81		K1-4	Stock water system	
	82		K5	Borehole pump	
83			K5	Stock water system: Pipeline	Survey / Design
Opgestel deur:			Rang	Kantoor	Datum
JJ Jordaan			Eng Tech	Mothibistadt	09/9/2019
Nagesien en Goedgekeur deur:			Rang	Kantoor	Datum
E Louw			Control Tech	Mothibistadt	09/9/2019

DEPARTEMENT VAN LANDBOU

Verwysing	Hoofkantoor Kimberley	Streek	JTG
Eienaar	RSA		
Plaaseenheid	Occidental Ranch 249	Landdrosdistrik	Kuruman
Weidingskapasiteit van veld	15 ha/GVE	Getal vee wat op die veld aangehou mag word	1672 GVE

LYS VAN GRONDBEWARINGSWERKE VOLGENS PLAASKAART No. 5/Occidental Ranch 249 Bladsy: 4

* Indien subsidie verlang word, mag nie met die oprigting van die voorgestelde grondbewaringswerk begin word alvorens skriftelike toestemming daartoe van die Uitvoerende Beampte ontvang is nie.

* Werke onder groep 1, is die voorgestelde grondbewaringswerke wat vir subsidie in aanmerking kan kom.

* Werke onder groep 2 is reeds gesubsidieer.

* Werke onder groep 3 word nie gesubsidieer nie.

Werk No. en Groep No.			Ligging volgens plaaskaart	Beskrywing en doel van werk	Afmetings
1	2	3			
	84		K5-8	Stock water system	Survey/ design
85			K13-16	Stock water system	Survey/ design
86			K9-12	Stock water system	Survey/ design
	87		K20	Borehole pump	Survey/ design
	88		K17-20	Stock water system	Survey/ design
	89		K28	Borehole pump	Survey/ design
	90		K25-28	Stock water system	Survey/ design
	91		K30	Borehole pump	Survey/ design
	92		K29,30	Stock water system	Survey/ design
	93		K32	Borehole pump	Survey/ design
	94		K31,32	Stock water system	Survey/ design
95			K22	Drilling Borehole	
96			K22	Testing Borehole	
97			K22	Borehole pump	Survey/ design
98			K21-24	Stock water system	Survey/ design
99			K10	Drilling Borehole	
100			K10	Testing Borehole	
101			K10	Borehole pump	Survey/ design
102			K32	Testing of Borehole	Final Report
103			K3	Sighting and Drilling of Borehole	Geo Report
104			K37, K38	Camp Fence	2412m
105			K38, K39	Camp Fence	1177m
106			K37, K40	Camp Fence	972m
107			K39, K40	Camp Fence	2430m
108			K33, K36	Camp Fence	2491m
109			K33, K34	Camp Fence	814m
110			K35, K36	Camp Fence	823m
Opgestel deur:			Rang	Kantoor	Datum
JJ Jordaan			Eng Tech	Mothibistadt	09/9/2019
Nagesien en Goedgekeur deur:			Rang	Kantoor	Datum
E Louw			Control Tech	Mothibistadt	09/9/2019

DEPARTEMENT VAN LANDBOU

Verwysing	Hoofkantoor Kimberley	Streek	JTG
Eienaar	RSA		
Plaaseenheid	Occidental Ranch 249	Landdrosdistrik	Kuruman
Weidingskapasiteit van veld	15 ha/GVE	Getal vee wat op die veld aangehou mag word	1672 GVE

LYS VAN GRONDBEWARINGSWERKE VOLGENS PLAASKAART No. 5/Occidental Ranch 249 Bladsy: 5

* Indien subsidie verlang word, mag nie met die oprigting van die voorgestelde grondbewaringswerk begin word alvorens skriftelike toestemming daartoe van die Uitvoerende Beamppte ontvang is nie.

* Werke onder groep 1, is die voorgestelde grondbewaringswerke wat vir subsidie in aanmerking kan kom.

* Werke onder groep 2 is reeds gesubsidieer.

* Werke onder groep 3 word nie gesubsidieer nie.

Werk No. en Groep No.			Ligging volgens plaaskaart	Beskrywing en doel van werk	Afmetings
1	2	3			
111			K34, K35	Camp Fence	2505m
112			K2, K3	Camp Fence	2058m
113			K1, K2	Camp Fence	1056m
114			K3, K4	Camp Fence	1044m
115			K1,K4	Camp Fence	2060m
116			K40,K41	Camp Fence	2062m
117			K41, K42	Camp Fence	1177m
118			K40, K43	Camp Fence	1263m
119			K42, K43	Camp Fence	2084m
120			K44, K45	Camp Fence	1598m
121			K45, K46	Camp Fence	1453m
122			K44, K47	Camp Fence	1457m
123			K46, K47	Camp Fence	1541m
124			K48, K49	Camp Fence	1528m
125			K49, K50	Camp Fence	1427m
126			K48, K51	Camp Fence	1431m
127			K50, K51	Camp Fence	1540m
128			K52, K55	Camp Fence	1537m
129			K52, K53	Camp Fence	1406m
130			K54, K55	Camp Fence	1411m
131			K53, K54	Camp Fence	1523m
132			K6, K7	Camp Fence	1541m
133			K7, K8	Camp Fence	1320m
134			K5 ,K6	Camp Fence	1322m
135			K5, K8	Camp Fence	1541m
136			K52 - K55	Stock Water System	Survey/ design
137			K48 -K51	Stock Water System	Survey/ design
Opgestel deur:			Rang	Kantoor	Datum
JJ Jordaan			Eng Tech	Mothibistadt	09/9/2019
Nagesien en Goedgekeur deur:			Rang	Kantoor	Datum
E Louw			Control Tech	Mothibistadt	09/9/2019

DEPARTEMENT VAN LANDBOU

Verwysing	Hoofkantoor Kimberley	Streek	JTG
Eienaar	RSA		
Plaaseenheid	Occidental Ranch 249	Landdrosdistrik	Kuruman
Weidingskapasiteit van veld	0 ha/GVE	Getal vee wat op die veld aangehou mag word	1672 GVE

LYS VAN GRONDBEWARINGSWERKE VOLGENS PLAASKAART No. 5/Occidental Ranch 249 Bladsy: 6

* Indien subsidie verlang word, mag nie met die oprigting van die voorgestelde grondbewaringswerk begin word alvorens skriftelike toestemming daartoe van die Uitvoerende Beampte ontvang is nie.

* Werke onder groep 1, is die voorgestelde grondbewaringswerke wat vir subsidie in aanmerking kan kom.

* Werke onder groep 2 is reeds gesubsidieer.

* Werke onder groep 3 word nie gesubsidieer nie.

Werk No. en Groep No.			Ligging volgens plaaskaart	Beskrywing en doel van werk	Afmetings
1	2	3			
138			K44 - K47	Stock Water System	Survey/ design
139			K40 - K43	Stock Water System	Survey/ design
140			K1 - K4	Stock Water System	Survey/ design
141			K37 -K40	Stock Water System	Survey/ design
142			K33 - K36	Stock Water System	Survey/ design
143			K50	Borehole pump	Survey/ design
144			K16	Stock Water System	Survey/ design
145			K16	Borehole pump	Survey/ design
146			K13	Borehole pump	Survey/ design
147			K3	Borehole pump	Survey/ design
148			K43	Handling facility	Design
149			K12	Handling facility	Design
Opgestel deur: JJ Jordaan			Rang Eng Tech	Kantoor Mothibistadt	Datum 09/9/2019
Nagesien en Goedgekeur deur: E Louw			Rang Control Tech	Kantoor Mothibistadt	Datum 09/9/2019